



# Viral Hepatitis (1)

**University of Jordan**

Malik Sallam, M.D., Ph.D.

School of Medicine

Department of Pathology, Microbiology and Forensic Medicine



# Overview

- Viral hepatitis is a **systemic disease** primarily involving the **liver** (i.e., it causes widespread systemic symptoms like fever, fatigue, jaundice, and nausea, ranging from self-limiting to fatal)
- Most cases of acute viral hepatitis are caused by one of the following agents: (HAV, HBV, HCV, HDV, and HEV).
- Hepatitis viruses produce acute inflammation of the liver, resulting in a clinical illness characterized by fever, nausea, vomiting, and jaundice.
- **Regardless of the virus type, identical histopathologic lesions are observed in the liver during acute disease.**

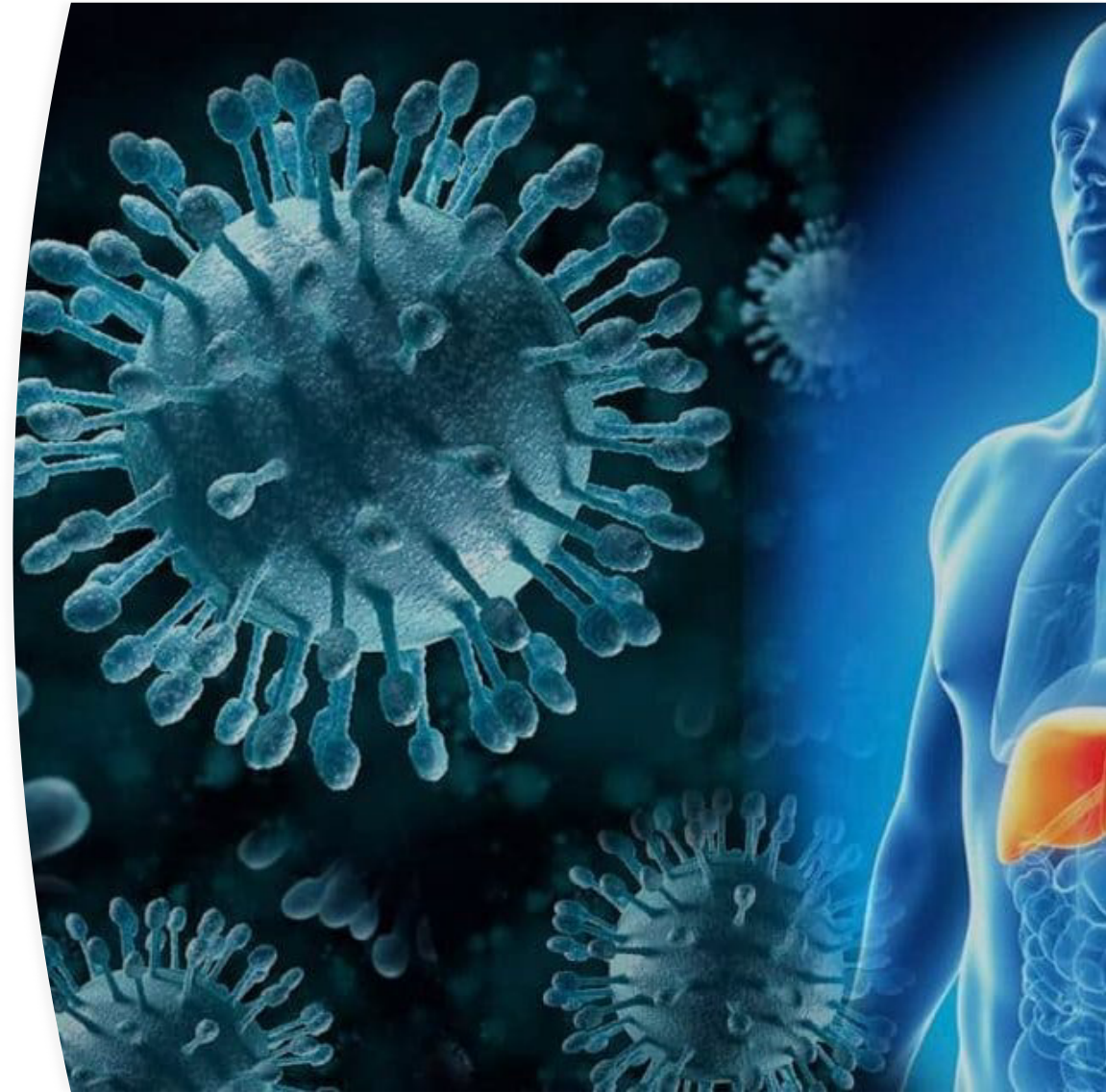



# Overview

- Acute hepatitis is a short-term infection (under 6 months) often causing intense, while chronic hepatitis is a long-term infection (over 6 months) that is frequently asymptomatic for years until significant liver damage, such as cirrhosis or liver cancer, occurs.
- Acute hepatitis results in jaundice, fatigue, nausea, vomiting, and abdominal pain, hepatomegaly, anorexia, low-grade fever, joint, and muscle pain, and dark urine.
- Chronic hepatitis usually no symptoms (asymptomatic) for years in the early phase. In the advanced stage with extensive liver damage, fatigue and unintentional weight loss occurs with easy bruising or bleeding, ascites, edema, hepatic encephalopathy (confusion, drowsiness, and slurred speech).

و كمان  
التهاب الكبد

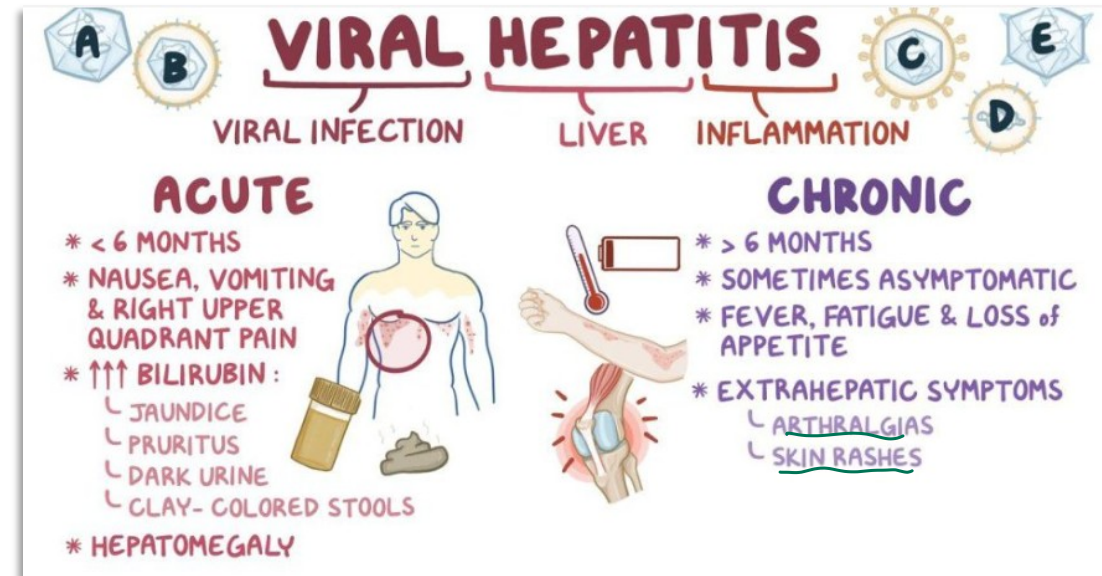



ع, أ, د, ب, ج



# Overview

<i>Virus</i>	<b>Hepatitis A</b>	<b>Hepatitis <u>B</u></b>	<b>Hepatitis C</b>	<b>Hepatitis D</b>	<b>Hepatitis E</b>
<i>Family</i>	<i>Picornaviridae</i>	<i>Hepadnaviridae</i>	<i>Flaviviridae</i>	Unclassified	<i>Hepeviridae</i>
<i>Envelope</i>	No	Yes (HBsAg)	Yes	Yes (HBsAg)	No
<i>Genome</i>	Positive ssRNA	dsDNA	Positive ssRNA	Negative ssRNA	Positive ssRNA
<i>Stability</i>	Heat- and acid-stable	Acid-sensitive	Acid-sensitive	Acid-sensitive	Heat-stable
<i>Transmission</i>	Fecal-oral	Parenteral	Parenteral	Parenteral	Fecal-oral
<i>Chronic disease</i>	Never	Often	Often	Often	Rare?



# Hepatitis A virus (HAV) - Overview

## Hepatitis A virus

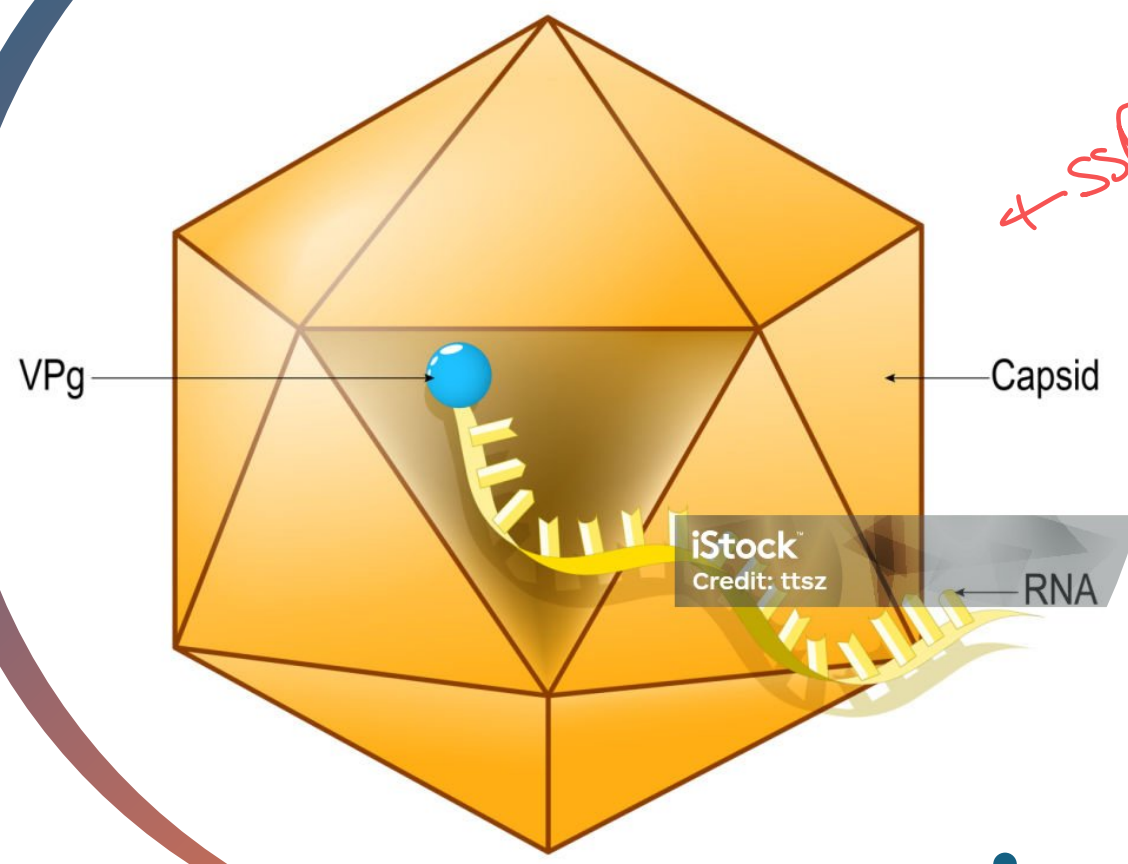

+ SSRNA

An RNA virus.

- Belongs to the *Picornaviridae* family.
- Positive-sense single-stranded RNA.
- Non-enveloped.
- HAV is stable at low pH.
- HAV has been found to survive for days to months in experimentally contaminated fresh water, seawater, wastewater, soils, marine sediment and live oysters.

العدوى الفيروسية



# HAV general features

# الفيروس لا يدخل بنصفه الخلية بل الإجابة المناعية .

- Transmission: Fecal-oral route (poor sanitation, overcrowding).
- Cellular receptors: Hepatitis A virus cellular receptor 1 HAVcr-1 (T-cell immunoglobulin mucin receptor 1; TIM-1).
- HAV is a 27- to 32-nm spherical particle with a linear single-stranded RNA genome with a size of 7.5 kb. 75000 base . + ssRNA
- Only one serotype is known. Genomic sequence analysis divided HAV isolates into seven genotypes.
- HAV is stable to treatment with 20% ether, acid (pH 1.0 for 2 hours), and heat (60°C for 1 hour), and its infectivity can be preserved for at least 1 month after being dried and stored at 25°C.

الفيروس يرتبط على هاد  
الريسبتور مع Hepatocyte

Serotype يعني  
الاستجاب المناعي للفيروس  
Genotype  
الفرق بين هذين هين  
في انزيمات الجينوم الكبير

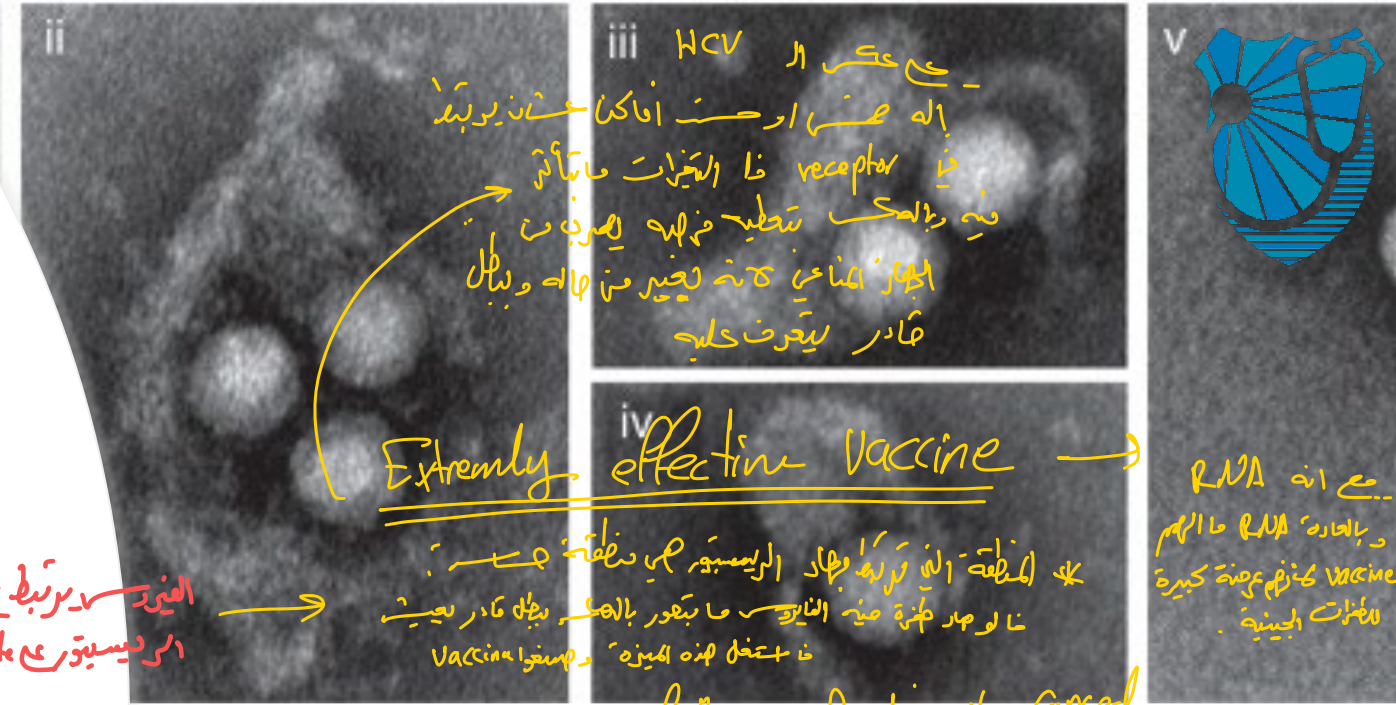

مع عكس ال HCV  
إله عكس ارحسنا افانكا عن تيربند  
في receptor فا الالتهابات ما تباقت  
فيه رد العكس بتطيق فيه يعرف  
المنزلة المناعي كانه يغير من حاله ويطول  
قادر يعترف عليه

Extremely effective vaccine →

كل المنطقة التي ترتبط بها الريسبتور هي منطقة حساسة  
ما لو جاد طيرة فيه الالتهاب ما بقدر بالهكس بطل قادر يعيد  
فا + عجل هذه المنزلة ورسبتورا Vaccina

مع انه RNA  
وبالعاده RNA ما الهم  
Vaccine كانه عينة كبيرة  
المنزلة الجينية .

The critical area of the virus found on the capsid so the vaccine target it easily and destroy it

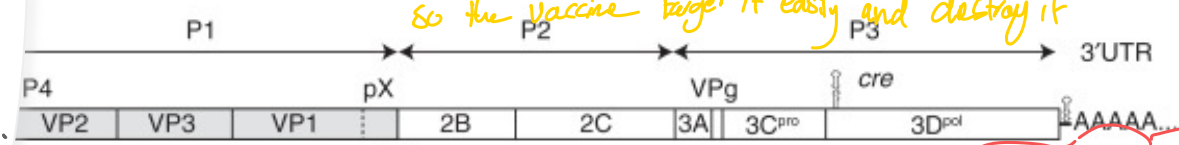

هو يعني + ؟  
يعني RNA نتجه جاهز بتايرة للبروتين  
ازله ما يدخل الخلية .

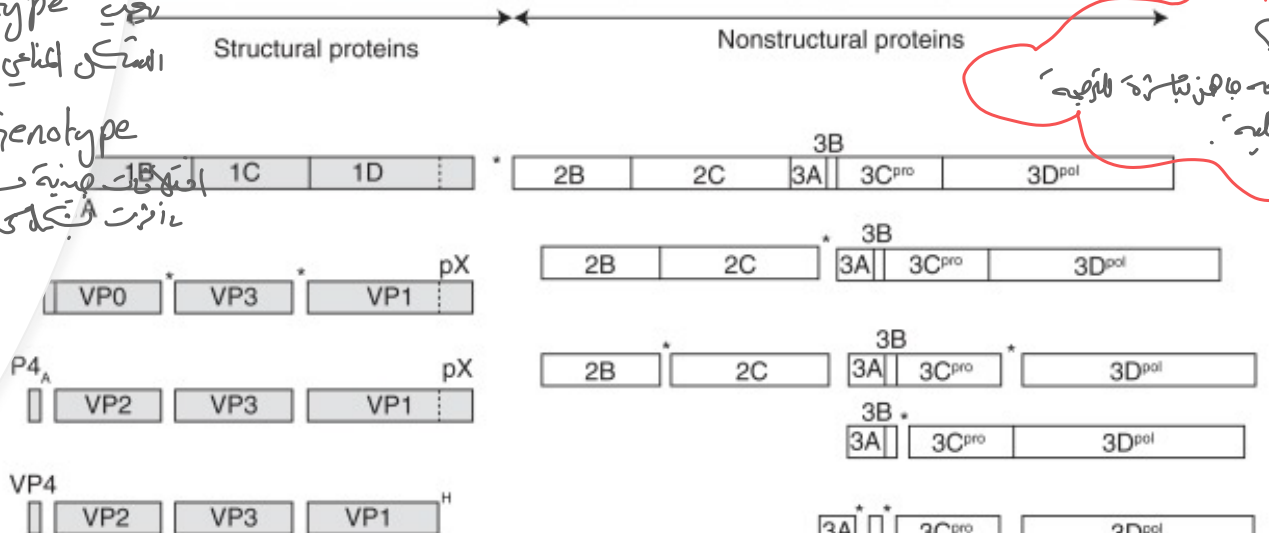



حادي الدكتور عاريم

# HAV general features



- The virus is destroyed by autoclaving (121°C for 20 minutes), boiling in water for 5 minutes, ultraviolet irradiation, treatment with formalin or treatment with chlorine.
- Heating food to above 85°C for 1 minute and disinfecting surfaces with sodium hypochlorite (1:100 dilution of chlorine bleach) are necessary to inactivate HAV.
- The relative resistance of HAV to disinfection procedures emphasizes the need for extra precautions in dealing with hepatitis patients and their products.



# Hepatitis A pathogenesis

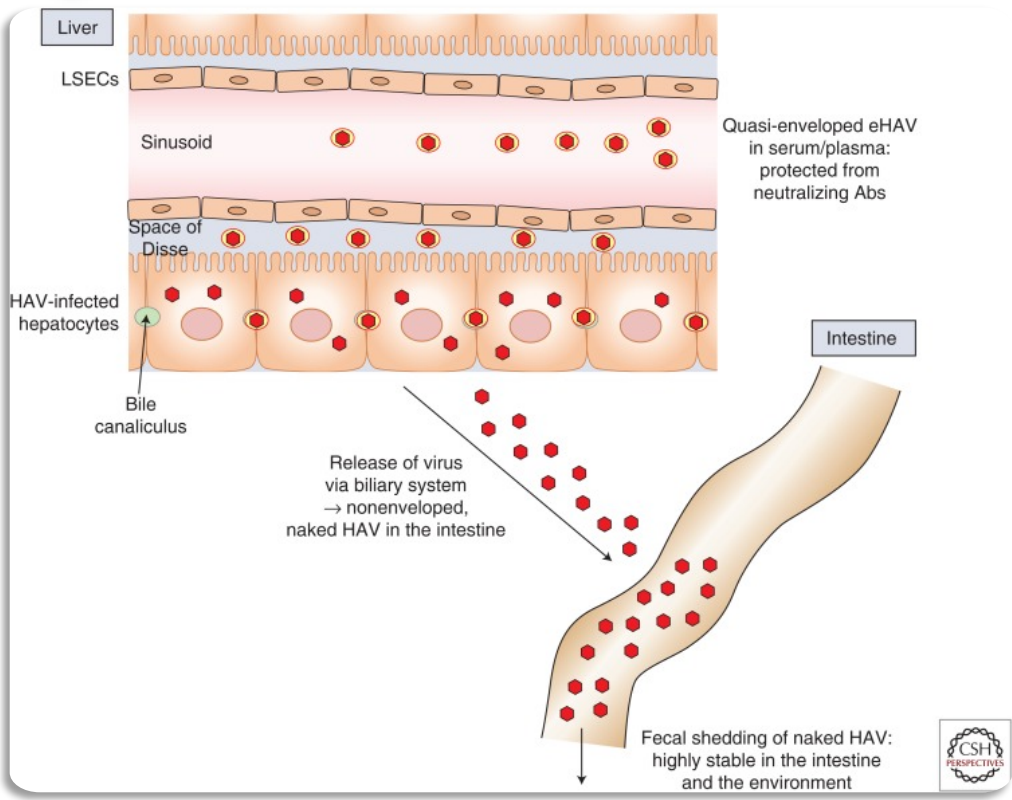

- HAV is spread by the fecal-oral route, most commonly by person-to-person contact. Common source outbreaks can occur.
- Non-enveloped, naked HAV is very stable and is shed in feces via the intestinal tract while preserving its infectivity.
- The primary site of replication for HAV is the liver, as demonstrated by virus detection in hepatocytes within days after infection.
- A relatively high concentrations of HAV are shed in the feces before the alanine aminotransferase (ALT) level initially becomes elevated and before the onset of clinical symptoms or jaundice.

Source: Shin, Eui-Cheol, and Sook-Hyang Jeong. "Natural History, Clinical Manifestations, and Pathogenesis of Hepatitis A." Cold Spring Harbor perspectives in medicine vol. 8,9 a031708. 4 Sep. 2018, doi:10.1101/cshperspect.a031708

هون الدكتور جباري انه الكمال  
 جهاز المناعة عندهم immature  
 عنان هياي ما يصح العيوس واصل نهران  
 انا الحصار بالنسبة جهاز المناعة عندهم mature ما يقدر يعالج الحصار  
 مناعة متقدمة مناعة متقدمة

أهم نقطة

- Liver injury in hepatitis A is caused by immune-mediated mechanisms involving both innate and adaptive immune responses to the virus

الخلاصة جهاز المناعة كقولنا اننا عنان من المناعة



# Hepatitis A - Clinical & Laboratory Findings

# الدكتور صبيح جابر الزنات دكتور

- Incubation period: 10-50 days (average, 25-30).
- Principal age distribution: Children, young adults.
- Seasonal incidence: Throughout the year but tends to peak in autumn.
- Route of infection: Predominantly fecal-oral.

ب- أعراض -  
 A + E → few weeks  
 B + C + D → months  
 and still depending on dose

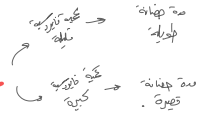

معناها  
 حتى لا يكون الفيروس  
 موجود في الدم

(سبوعين - أسبوع به)  
 (بعض - ايامان)

• Occurrence of virus in blood: 2 weeks before to ≤1 week after jaundice.

• Occurrence of virus in stool: 2 weeks before to 2 weeks after jaundice.

حتى لا يكون الفيروس موجود في الدم

(سبوعين - أسبوعين)  
 (بعض - بضع)



# Hepatitis A - Clinical & Laboratory Findings

- Onset: Abrupt (sudden).
- Fever: Common.
- Duration of aminotransferase elevation: 1-3 weeks.
- Complications are uncommon, no chronic state.
- Patients with inapparent or subclinical hepatitis have neither symptoms nor jaundice. *(بعض غير ظاهر)*
- Other patients can develop anicteric hepatitis or icteric hepatitis. *→ هذا الفئتين اعتماداً على وجود وعدم وجود Jaundice*
- Symptoms ranging from mild and transient to severe and prolonged can accompany anicteric or icteric hepatitis.
- Most patients recover completely; however, some develop fulminant hepatitis and die. *مع كل أنواع liver hepatitis من أمثاله يحدث له من شدة به - viral*

	AST	ALT
Alcoholic hepatitis	↑↑↑	↑
viral hepatitis	↑	↑↑↑

*Elevated liver enzymes* *منه يكون من الامرين يكون منه* *دعيان* *سبب* *عائنه* *اعراض* *دايمه* *ملا* *يرقان*

*صايه الكاهه اكر* *عند الة* *نقله*

*26*

*مع كل انواع liver hepatitis من أمثاله يحدث له*

*من شدة به - viral*



# Hepatitis A – Clinical & Laboratory Findings

**Fulminant hepatitis =**  
rapid acute liver failure  
+  
hepatic encephalopathy

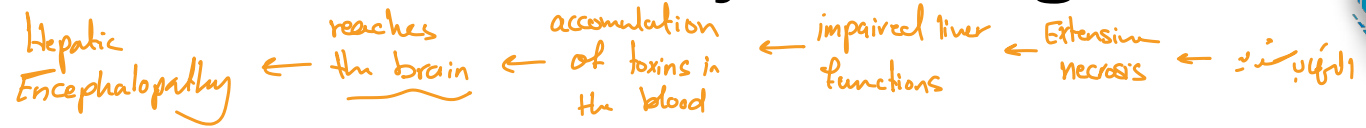

- Occasionally, more extensive necrosis of the liver occurs during acute viral hepatitis A, leading to severe impairment of hepatic synthetic processes, excretory functions, and detoxifying mechanisms.
- This entity, designated fulminant hepatitis if hepatic encephalopathy occurs during the first 6 to 8 weeks of illness or within 1 to 4 weeks after jaundice, is characterized by the sudden onset of high fever, marked abdominal pain, vomiting, and jaundice followed by the development of encephalopathy associated with deep coma and seizures.
- So, fulminant hepatitis can be defined as the rapid development of acute liver failure and hepatic encephalopathy (confusion or coma)



# Hepatitis A – Clinical & Laboratory Findings

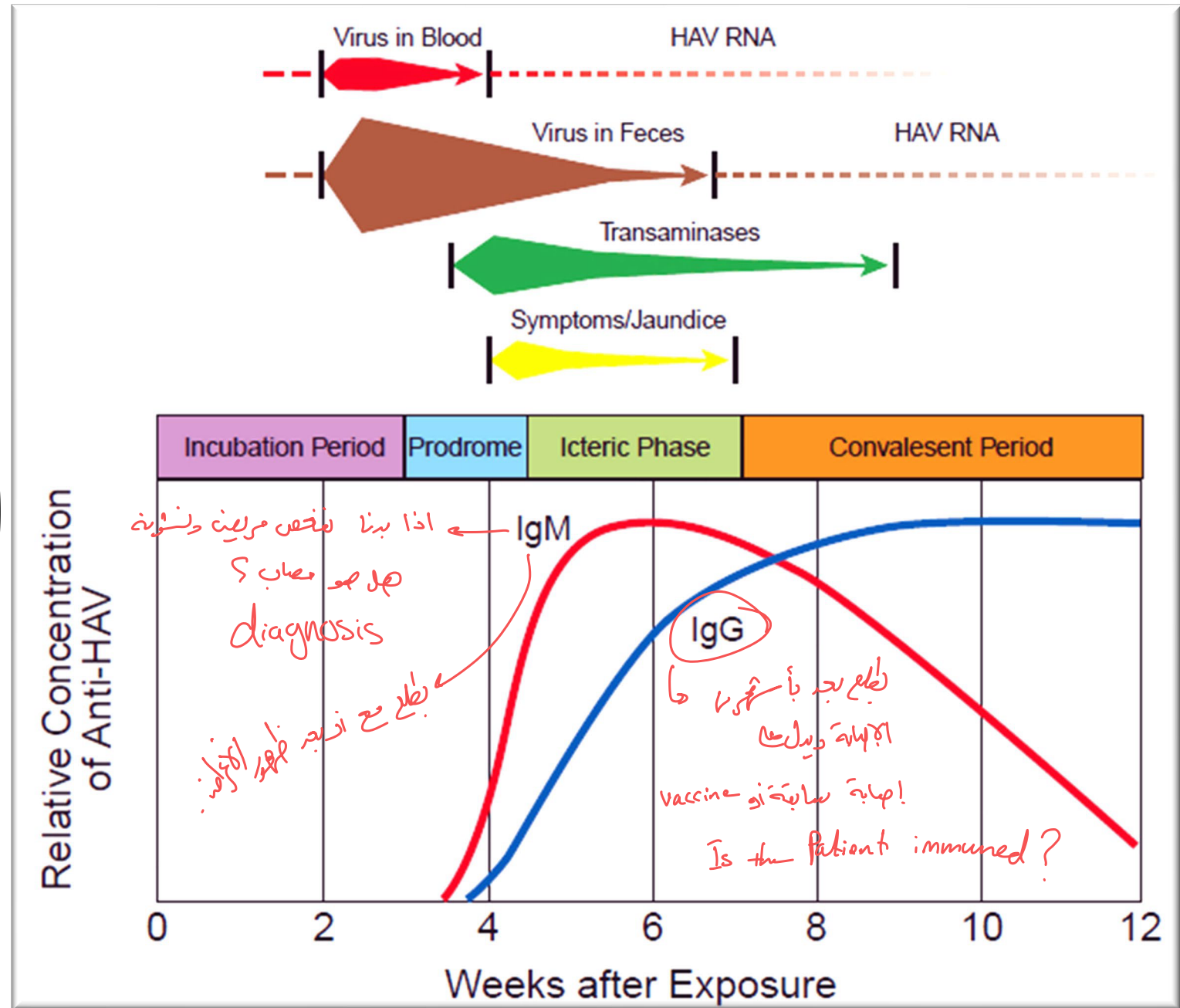



# Hepatitis A - Epidemiology

- Hepatitis A is one of the most common causes of infectious jaundice in the world today and is frequently associated with recurrent epidemics.
- HAV communicability is apparently highest during the clinically silent incubation period when virus replication reaches a peak.

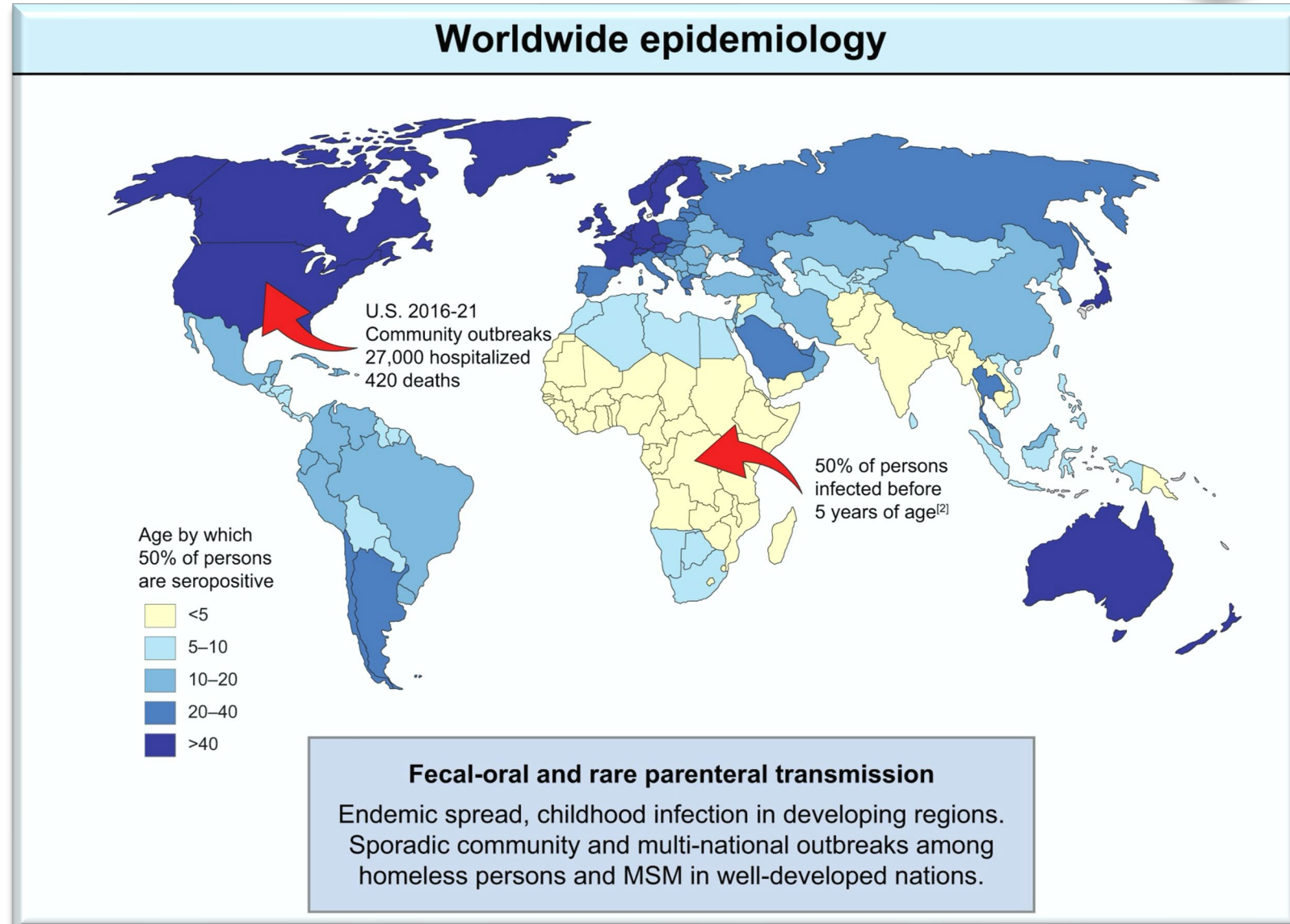



Paradox؟ دوره عندها Immunology في طار ملوث  
 اعنارة (2)

دبالتالي الاطفال عندهم اكثر للهرس وبتناغار صغيرة  
 بالتالي الاطفال جرحونوا (Asymptomatic) وبتنيس  
 عندهم مناعة life long وبتنيس حيتي الاجتوب من outbreak  
 وبتنيس  
 اذا ابلان الطفلية في الاطفالا محصية وبتنيس عما يجربوا مني مناعة ضد الهمون عندهم خطر outbreaks عالي  
 دكانهم فيهم صاه البلدان منطاعيم

# HAV epidemiology paradox

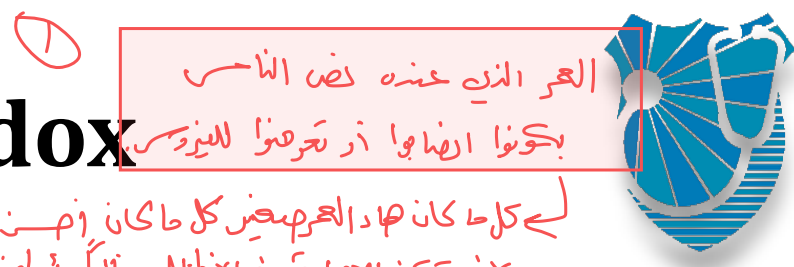

لعي كل ط كان هاد العمر مخص كل ط كان ارضاب  
 كانه بتكون الالهاية بين الاطفال وعلابا باراضاب  
 مخصية اذ بعت

ولكن لو كان العمر كبير في يعني الالهاية بين الكبار  
 دبالتالي اراضاب دامتة وهالات دخول في اعراض بازدياد  
 وبتنيس تطور في ال  
 outbreaks (نكبة)

- The phenomenon where improved sanitation and living standards in developing regions, which reduces the overall transmission of HAV, paradoxically leading to an increase in clinical morbidity and mortality.
- While HAV is self-limiting in children, it causes jaundice in 40–70% of adults and can lead to severe morbidity.
- The shift means countries moving from high to intermediate endemicity often see a rising need for universal vaccination programs to protect the now-susceptible adult population

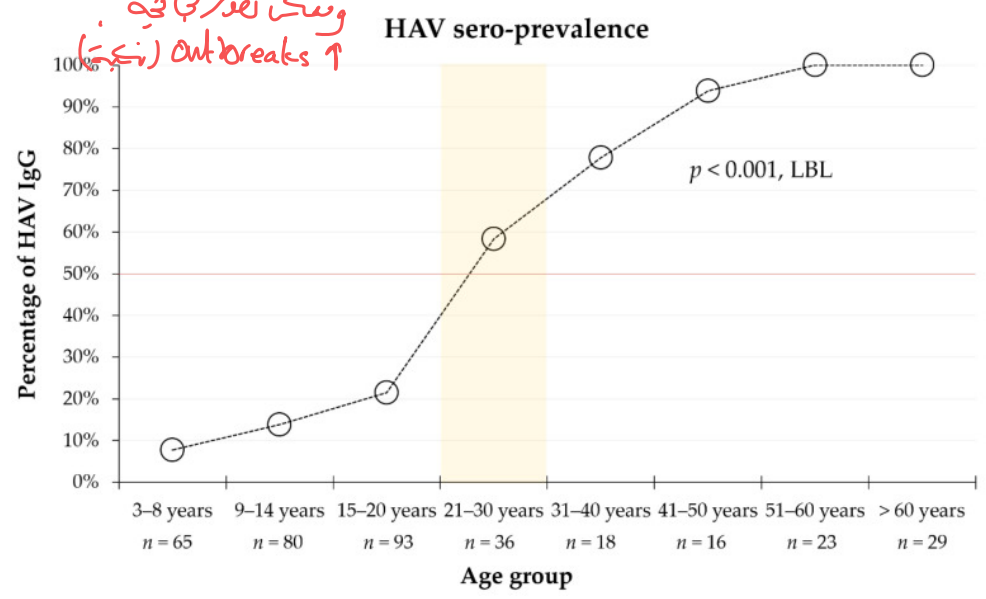



# Hepatitis A – Diagnosis, Management, and Prevention

- LFTs; Antibody detection: HAV-specific **IgM** antibodies are typically found in the **earliest stage of disease and can last for six months after infection.** **IgG** antibodies can **last for many years**; Molecular detection: HAV RNA in serum or stool
- No specific treatment for acute viral hepatitis exists, and hospitalization is not ordinarily indicated. Therapy should be supportive and aimed at maintaining comfort and adequate nutritional balance.
- **Formaldehyde inactivated vaccines** are available worldwide.
- In China, three formaldehyde-inactivated and two live attenuated monovalent HAV vaccines are available

live attenuated  
vaccine

الدكتور اجتهاد ان inactivated vaccine كاني بالخريف و ماضي داعي للظوم الصيني



# Hepatitis E Virus (HEV) - Introduction

Enteric

Zoonotic  
 HEV  
 WAV  
 They are very similar  
 ↓  
 No Specificity  
 ↳ similar manifestation between  
 so we do serology test for all types of viruses  
 Peccal oval  
 non enveloped  
 R.NA viruses of  
 acute hepatitis



- Previously labeled enterically transmitted non-A, non-B hepatitis, HEV is an enterically transmitted virus that occurs primarily in India, Asia, Africa, and Central America; in those geographic areas, HEV is the most common cause of acute hepatitis.
- This agent, with epidemiologic features resembling those of hepatitis A, is a 32- to 34-nm, nonenveloped, HAV-like virus with a 7.6 kb, single-strand, positive-sense RNA genome.

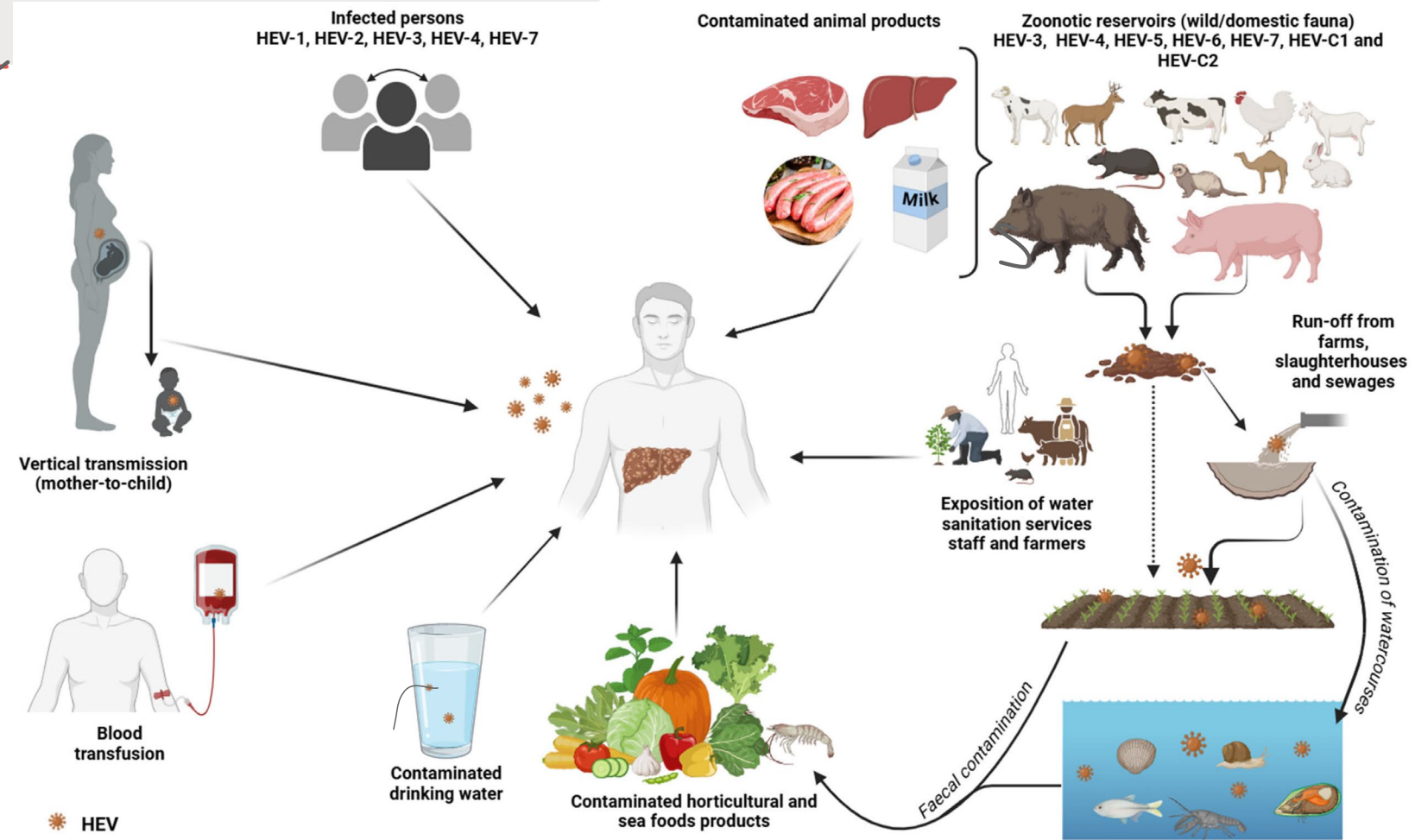

\* In pregnant women the severity of acute hepatitis by HEV is very stronger than others.



# HEV

إحدى بالرغم من الاختلافات الجينية لتورات الفيروس  
صهاج المناعة بشو فهم كلهم نفس الـ (Single Serotype)

لكن إنا المسبحون antibodies عندنا  
غالباً ليس عنده حماية ضد الفيروس أيضاً.

- All HEV isolates appear to belong to a single serotype, despite genomic heterogeneity of up to 25% and the existence of five genotypes, only four of which have been detected in humans; genotypes 1 and 2 appear to be more virulent, while genotypes 3 and 4 are more attenuated and account for subclinical infections.

- Contributing to the perpetuation of this virus are animal reservoirs, most notably in swine.

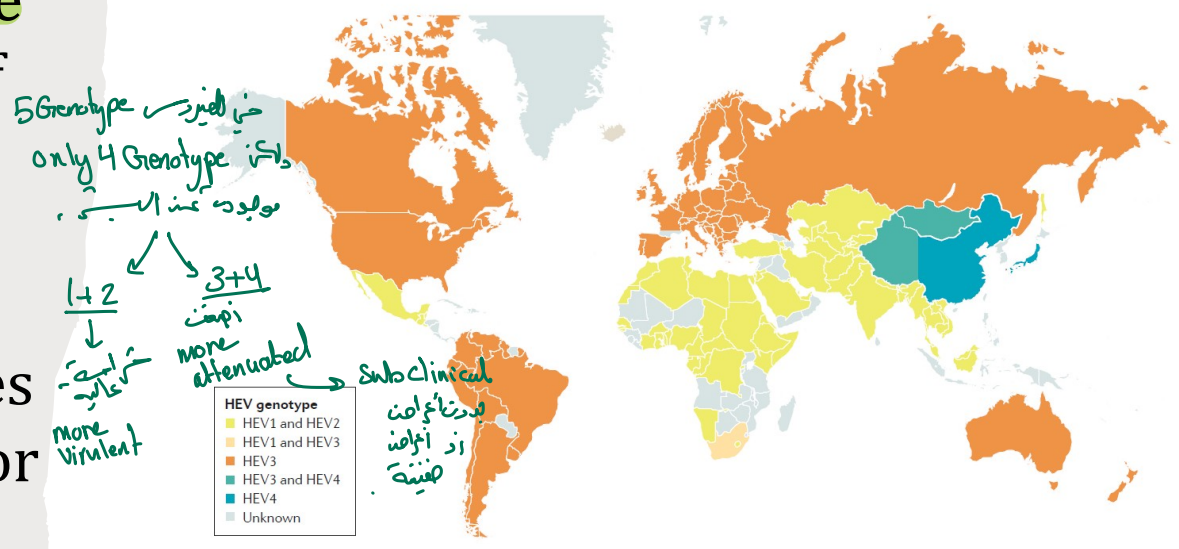



# Hepatitis E Virus

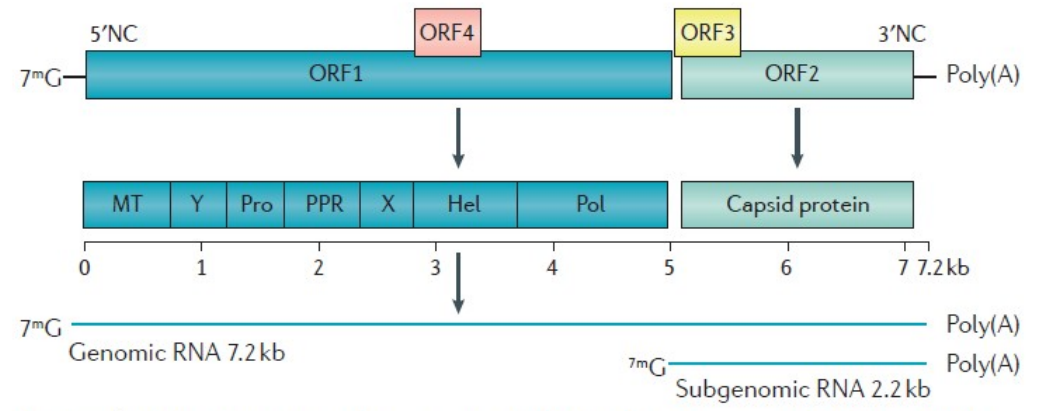

There is **no genomic or antigenic homology**, however, between HEV and **HAV** or other **picornaviruses**; and **HEV**, although resembling **caliciviruses**, is sufficiently distinct from any known agent to merit a new classification of its own as a unique genus, *Hepevirus*, within the *Hepeviridae* family.

حاميًا ضد بكتيريا الزائدة

و لا تتعرف عليها المناعة إلى تتعرف عليها المناعة

HEV و HAV  
يعملوا نفس العمل  
الطبيعية - لكنهم مختلفين  
biologically  
في وظائف العائلة

ليس مهم أن يكون أنه ما في تفرقة معينة؟  
• لقاحات معينة  
• مناعة معينة  
• تكاثر فيروس معين  
كليا مختلف

### Similar disease ≠ same virus family

- هاي قاعدة ضخمة بالميكرو.  
ممكن فيروسين:
- يعملوا نفس المرض
  - ينتقلوا بنفس الطريقة
  - لكن: تركيبهم الجيني مختلف تمامًا.



# Hepatitis E - Pathogenesis



- Entry of HEV into the host is by the oral route.
- The incubation period ranges from 2 weeks to 2 months.
- HEV replicates in the cytoplasm of hepatocytes and is released into the bile and blood.
- Viremia and fecal shedding are first detected about 3 weeks after exposure and about a week before onset of disease.
- Liver enzyme values peak about 7 to 8 weeks post exposure. Viremia may diminish at that time; however, fecal shedding may continue for days to weeks.
- Mortality of hepatitis E has varied in different reports but has been as high as 1%, compared to 0.2% for hepatitis A.

mortality → HEV → 1%  
 → HAV → 0.2%

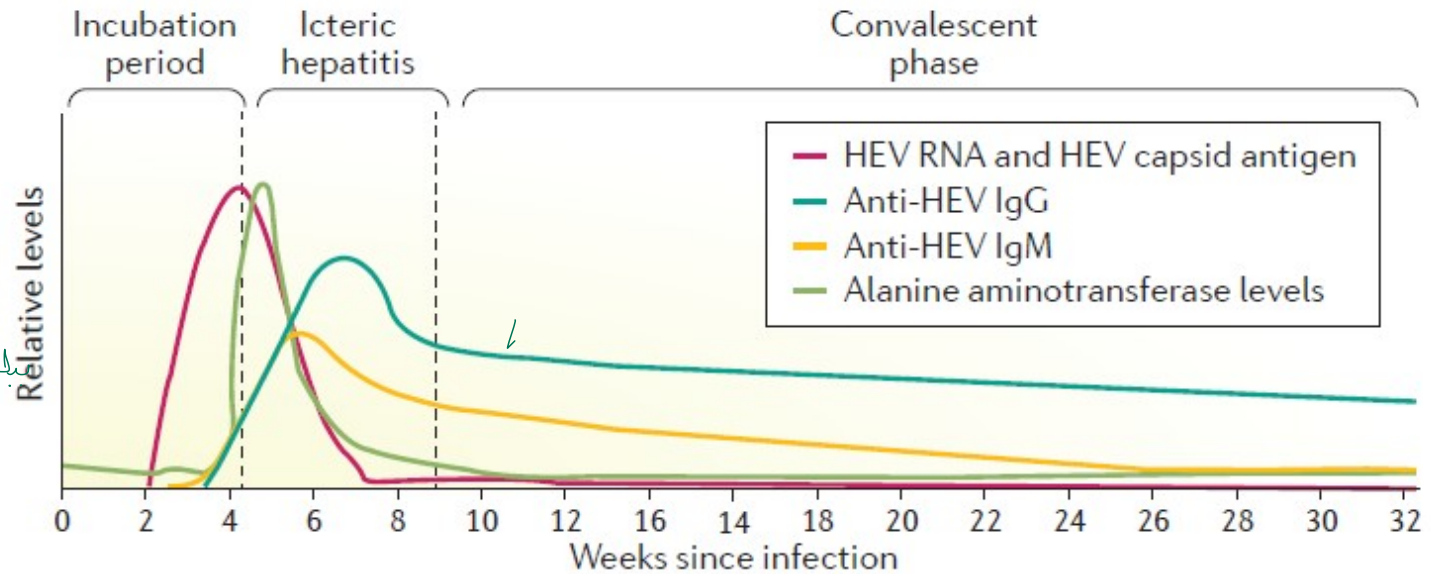
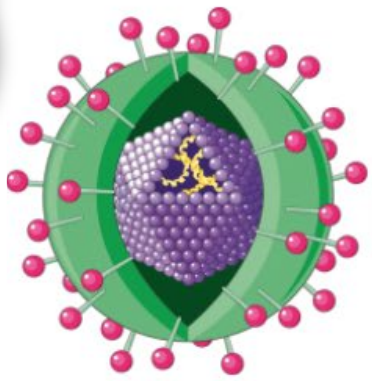
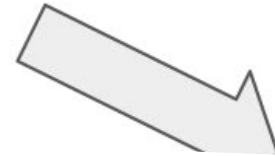
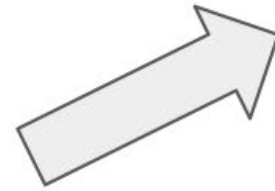
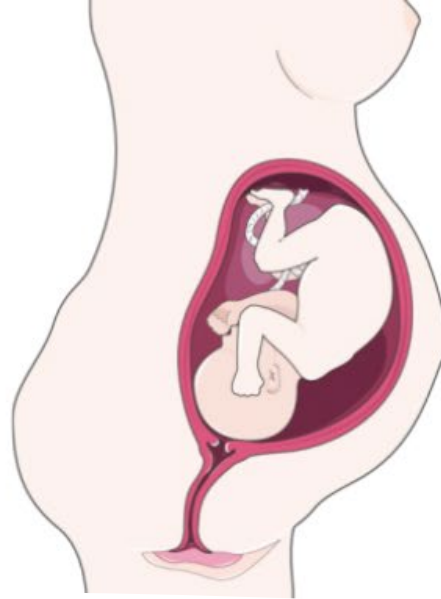

Figure 4 | HEV infection and hepatitis E. Appearance of hepatitis E virus (HEV) RNA, capsid proteins and antibodies during HEV infection. IgG, immunoglobulin G; IgM, immunoglobulin M.



HEV infection



Hormonal changes

Altered immune regulation

Viral factors

Liver damage



## Hepatitis E – Pathogenesis

- More important, however, is the severity of hepatitis E in pregnant women, which may reach 20%.
- The reason for the excessive mortality of hepatitis E in pregnancy is unknown, although a high viral load and abnormalities of progesterone signaling pathways have been suggested.
- Although most HEV infections are self-limiting and resolve without sequelae, a significant proportion (>50%) of infected organ transplant patients or those with other types of immunosuppression may develop chronic infection that can progress to chronic hepatitis and cirrhosis.



# Hepatitis E – Diagnosis and Management

- Definitive diagnosis of hepatitis E infection is usually based on the detection of specific anti-HEV IgM antibodies to the virus in a person's blood. Rapid tests are available for field use.
- Additional tests include reverse transcriptase polymerase chain reaction (RT-PCR) to detect the hepatitis E virus RNA in blood and stool.
- No specific treatment exists for acute hepatitis E. Both interferon alpha and ribavirin have been used successfully to treat chronic HEV infections.
- Hospitalization is required for people with fulminant hepatitis and should also be considered for symptomatic pregnant women.

General  
Anti-viral  
effect

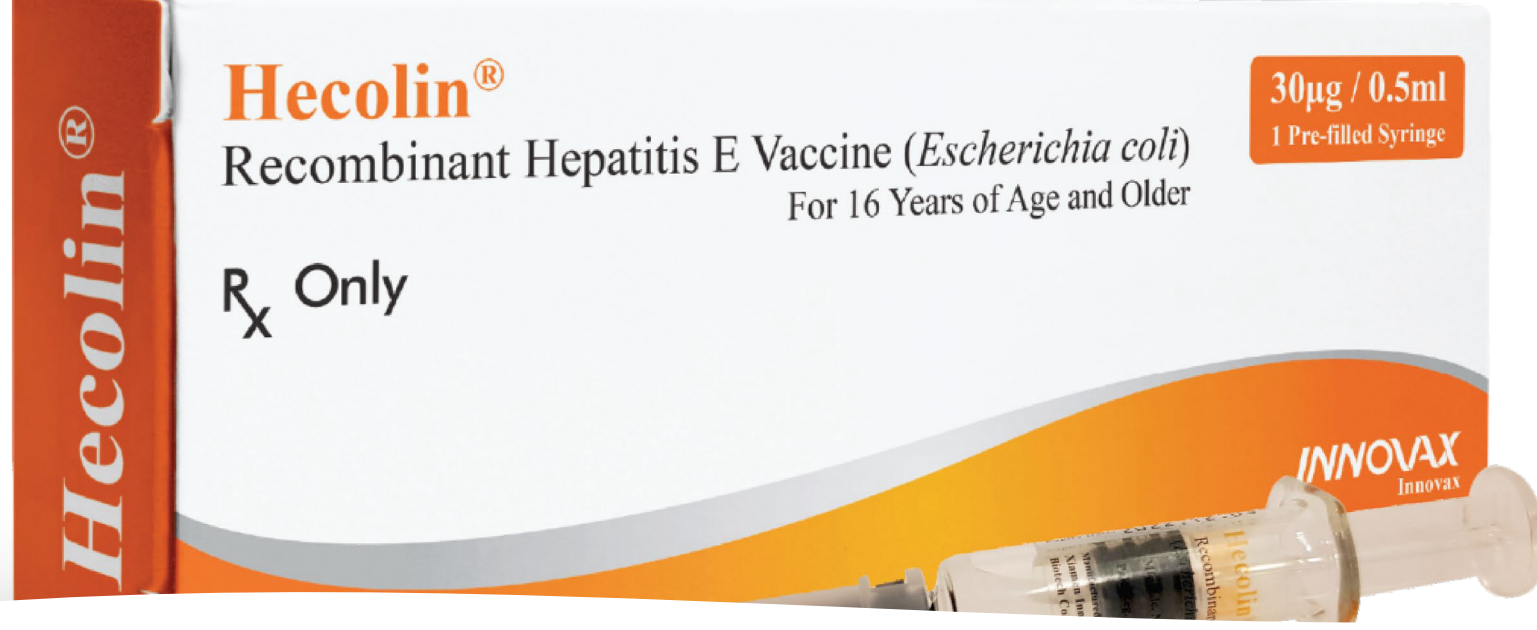
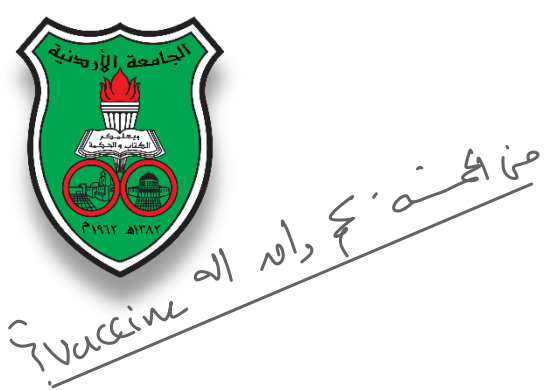

- HEV prevention and disease control therefore primarily rely on water, sanitation, and hygiene (WASH) measures.
- The development of the **only currently available Hepatitis E vaccine**, known as HEV 239 vaccine (**Hecolin®**), marks an opportunity to protect vulnerable populations and curb disease outbreaks.
- The **recombinant vaccine** has been licensed for use in healthy adults aged  $\geq 16$  years in China since 2011 via intramuscular injection using a **3-dose schedule** (0, 1 and 6 months). The product is supplied in a pre-filled syringe with an approved shelf life of at least 36 months. In a large, phase III clinical trial in China, it exhibited a high efficacy rate and exhibited a good safety profile, notably in adults aged  $\geq 16$  year

## Hepatitis E – Prevention